

## **Raptor Acuity and Wind Turbine Blade Conspicuity**

by

*Hugh P. McIsaac*

Raptor Research Center, Boise State University<sup>1</sup>

### **Introduction**

This report summarizes the results of several studies that were undertaken in an effort to increase the conspicuity of wind turbine blades and reduce raptor fatalities in the wind resource area of the Altamont Pass in central California. The Altamont Pass contains a commercial wind plant that converts wind energy into electricity using large wind turbines. Unfortunately, the wind turbines kill some birds (Orloff and Flannery 1992). Furthermore, relative to other bird species in the area, the turbines kill a disproportionate number of diurnal raptors (Howell and DiDonato 1991, Howell and Noone 1992, Orloff and Flannery 1992). The incidence of raptor deaths at turbines is relatively rare (0.02-0.05 per turbine per year), and only a few collisions have been directly observed; in most cases dead birds are found near the bases of turbines. There are very few data to suggest the circumstances, and bird behaviors, associated with collisions. Kenetech Windpower, Inc., now Green Ridge Power, Inc., is a major operator of wind turbines in the area, and in 1992 this company convened a panel of biologists, called the Avian Task Force, to provide advice about how to reduce the risk of bird collisions with the turbines (Gipe 1995).

The Avian Task Force reviewed the reports and data assembled to date, and considered a variety of scenarios that might contribute to collisions between birds and wind turbines. They then evaluated a variety of practical management actions that might be used to reduce the fatalities. The Task Force concluded that bird vision likely was the most important factor for understanding the problem, and, thus, in implementing a solution. The anatomy and physiology of raptor vision have received considerable attention (e.g., Frost et al. 1990, Inzunza and Bravo 1993, Inzunza et al. 1991, Meyer 1977, Shlaer 1972, Snyder and Miller 1978, Walls 1942), but there is a paucity of measures concerning how birds, especially raptors, behave in response to complex stimuli under diverse circumstances (e.g., Emmerton 1990). Consequently, we have little behavioral information from which to infer bird-vision capabilities and limitations, and, thus, a poor basis for predicting how changes in a raptor's visual environment will affect its behavior. On the basis of the Task Force's recommendation, several behaviorally-based studies of raptor visual capacity were undertaken to determine whether the vision of raptors enabled clear resolution and localization of turbine blades.

With the help of several colleagues and assistants, I directed seven studies concerning

---

<sup>1</sup> Department of Biological Sciences, F.W. Olin Science Hall, University of Denver, 2190 E. Iliff Ave., Denver, CO 80208-2601. *Phone:* (303) 871-2229. *E-mail:* hmcisaac@du.edu

raptor visual acuity and the capacity of raptors to see wind-turbine blades. This work was conducted between 1993 and 1996 at the Raptor Research Center, Boise State University, Boise, ID. What follows is a brief summary of this work; a detailed report of each study has been submitted to the National Renewable Energy Laboratory (NREL) [McIsaac, McIsaac and Chastain, McIsaac et al., McIsaac and McDonald (a), McIsaac and McDonald (b), McIsaac and Whitlock (a), McIsaac and Whitlock (b)], along with an extensive summary (McIsaac and Fuller).

The goal driving this research was to design patterns that could be painted on wind-turbine blades in order to make them more conspicuous to birds in flight than are the uniformly off-white blades now used by many wind-energy companies. Our studies involved basic research of bird visual acuity, and the conspicuity of blade patterns. Results from our first few studies indicated that the visual acuity of raptors was insufficient to resolve and localize turbine blades under some conditions, and that the application of a pattern to the blades might reduce this problem. Several patterns were tested in an attempt to develop a pattern that when applied to the blades of turbines would alert raptors to the presence and location of the blades. This report summarizes the results of our studies, specifically as it relates to the raptors' abilities to detect and locate wind turbines.

Our studies followed three different approaches designed to determine how well raptors resolve visual features and their capacity to see turbine blades. First, we tested raptor acuity using both stationary and rotating stimuli. Second, we tested the conspicuity of patterns on turbine-like blades, and, third, we tested raptors' capacity to group turbines into a cognitive category. These studies involved two species of raptors, the American kestrel (*Falco sparverius*), and the Red-tailed Hawk (*Buteo jamaicensis*). In addition, one study measured the conspicuity of patterns as a function of human perception.

## General Methods

Behavioral-conditioning methods provided the basis to test raptor acuity and pattern conspicuity. Most of these studies involved standard two-stimulus forced-choice procedures (Blough and Blough 1977) to train and test each bird to discriminate between test and control stimuli. Study 7, a test of kestrel capacity to group images of turbines into a cognitive category, involved a modified go/no-go procedure (Blough and Blough 1977).

In two-stimulus forced-choice procedures test and control stimuli, positioned side by side, were presented simultaneously to the test bird. The bird received a food reward each time it correctly indicated which of the two stimuli presented the test stimulus; the food rewards reinforced the bird's behavior and encouraged it to repeat the action. Selection of the control stimulus generated a short delay and no food reward. We randomly switched the test stimulus between left and right stimulus-presentation positions. Thus, the bird could not predict on which side the test stimulus would appear. Eventually the bird learned to reliably indicate on which side the test stimulus was positioned, as evidenced by a higher proportion of correct responses. After the bird had learned to reliably discriminate the stimuli, the visual condition under which test and control stimuli were presented was changed so that discrimination of test and control stimuli became more difficult. For example, in the acuity studies (see below), the widths of the parallel black-and-white lines that

composed the test stimulus pattern were narrowed, making the lined stimulus more difficult to distinguish from the uniformly gray control stimulus. The bird's capacity to discriminate was again tested but under the new visual conditions. As the visual conditions "deteriorated" the difference between test and control stimuli became difficult for the bird to detect, and the proportion of correct discriminations declined. Eventually, the test stimulus become too difficult for the bird to detect, and its discrimination rate fell to random; with two stimuli this corresponds to a discrimination level near 50%. With the exception of Studies 1 and 5, computers were used to control the experiments and associated apparatus. The computers randomized the sequence of stimulus presentations (i.e., the left or right position of the test stimulus), monitored the birds' responses and recorded the data, and controlled the food-delivery component of the apparatus, dispensing food rewards for correct discriminations of test stimuli.

In our four studies of raptor acuity (Studies 1-4), we trained birds to discriminate between uniformly gray fields and square-wave gratings of alternating black-and-white lines. Within a given test stimulus the widths of all lines, black and white, were the same. However, several different test stimuli were presented to the birds, and these differed in line width. The birds' discrimination performances tended to be high with wide lines and declined toward random with progressively narrower lines. Following convention, we defined acuity to correspond to the line widths associated with 75% correct discrimination (e.g., Blough 1973, Hodos et al. 1985, Harvey 1986). Also by convention, test-stimulus line widths and acuity are reported in cycles/degree, (cyc./deg.; Hodos et al. 1985, Hahmann and Güntürkün 1993); this standardizes stimulus-image size on the birds' retinas independent of the distance separating the bird and stimulus.

## **Study Descriptions, Results, and Discussion**

*Study 1 - Visual Acuity of the American Kestrel* (McIsaac, et al. - submitted to NREL). To better understand how well raptors see detail in objects such as wind turbines, and the role of distance in visual performance, we measured the visual acuity of the American kestrel. Visual acuities of four kestrels were obtained at several stimulus-presentation distances (SPD), i.e., the distances separating the subjects from the stimuli. This study was conducted by hand, with a technician manually setting up the apparatus and stimuli, observing the bird's behavior, rewarding the bird, and recording the data. The birds indicated their left-hand or right-hand stimulus selection by hopping from a starting position toward the selected stimulus; each stimulus had a perch in front of it on which the bird could land. This procedure has been used in most earlier studies of raptor acuity (Fox et al. 1976, Hirsch 1982, Reymond and Wolfe 1981, Reymond 1985). The assumption in these studies has been that the bird discriminated the test and control stimuli while at the starting position, before moving toward the stimuli, yet discrimination could occur during the bird's movement toward the stimuli. Thus, the distance at which the bird actually discriminates between the test and control stimuli is unknown. Incomplete control of the distance between bird and stimulus may have allowed birds to discriminate the stimuli at distances shorter than the SPDs and this could inflate the acuity estimates.

The results obtained in our study were as follows. Three birds exhibited similar acuities, 16.5, 21.7, 19.5 cyc./deg., at an intermediate distance of 92 cm. Two of these birds also were

tested at a longer SPD, 160 cm. At 160 cm one bird showed twice the acuity, 40.5 cyc./deg., of its intermediate-SPD acuity, while the second bird showed an acuity, 19.2 cyc./deg., similar to its intermediate-SPD acuity. We obtained a third acuity of 15.9 cyc./deg. from one of the kestrels at a second intermediate SPD of 76 cm. A single acuity was obtained from the fourth kestrel at a 50 cm SPD; this acuity estimate, 4.9 cyc./deg., was considerably lower than any of the acuities obtained from the other kestrels. The results obtained suggest that the acuity of the American Kestrel is on the order of 20 cyc./deg. This is less than half the acuity of humans and conflicts with common-lore notions of exceptional acuity in diurnal raptors (e.g., Fox et al. 1976, Johnsgard 1990, Walls 1942).

***Study 2 - Spatial Visual Acuity in American Kestrels and the Influence of Bird-Stimulus Distance on Acuity*** (McIsaac and Whitlock (a) - submitted to NREL). During the course of Study 1 we became concerned that incomplete control of the distance at stimulus discrimination may have produced inflated acuity measurements in our study (McIsaac et al. - submitted to NREL) and in previously published reports (Fox et al. 1976, Hirsch 1982, Reymond 1985, Reymond and Wolfe 1981). To address this concern we repeated our study of visual acuity using an automated apparatus that controlled stimulus-discrimination distance (SDD). Visual acuities of five American kestrels were obtained at several SPDs: 21 cm, 92 cm (or 100 cm), and 200 cm. Training and testing of the kestrels in this study was automated so that stimulus presentation, monitoring of the bird's responses, delivery of food rewards, and data collection were controlled by computer. During an experiment the bird perched near two windows in the front of a small box. The windows directed the bird's view toward each of the two stimuli, with only a single stimulus visible through a given window. The bird indicated its selection of one stimulus or the other by extending its head into the window directed at the selected stimulus. The bird's head interrupted an infrared light beam that traversed the window, and the computer recorded the interruption. Successful discriminations of the stimuli were rewarded with the delivery of food through a small port located slightly below and between the two windows in the front of the box. Food rewards were extruded from a syringe and consisted of ground quail meat (see Fig. 1). This procedure completely controlled the distance at which the kestrels discriminated the stimuli, SDD, and prevented inflation of acuity estimates. In this case SPD equals SDD.

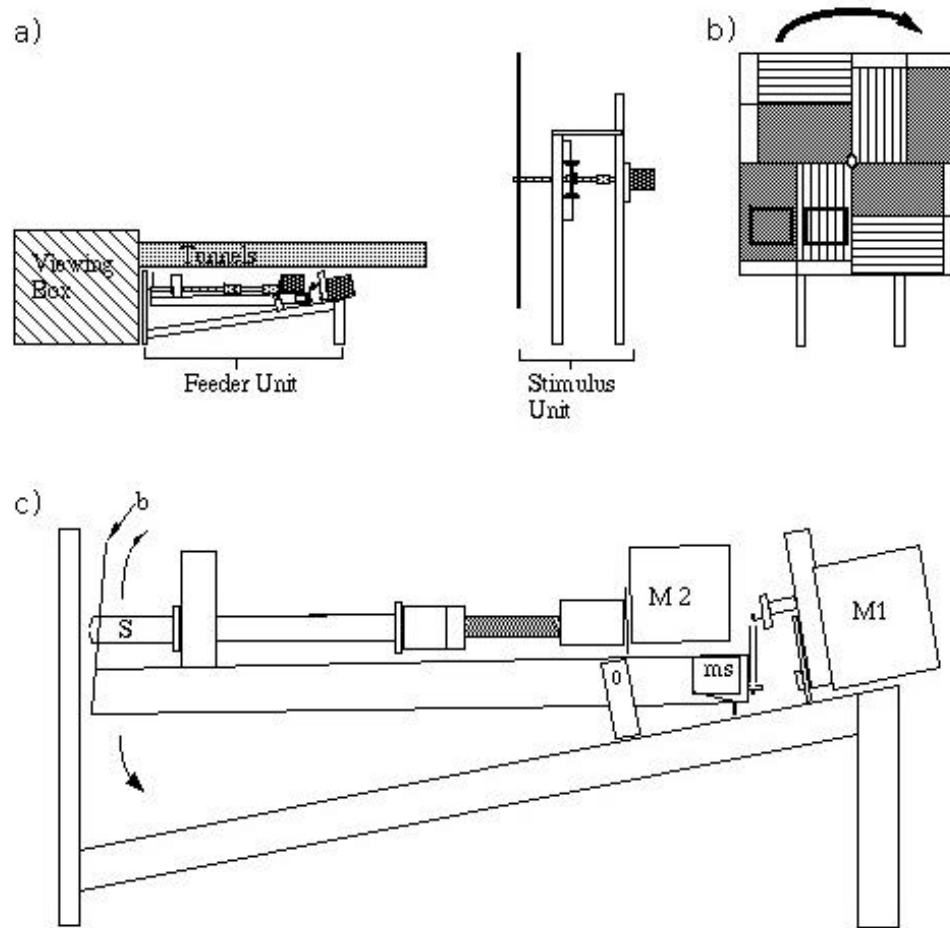

FIGURE 1. Apparatus used to test kestrel spatial visual acuity. The apparatus consisted of three major components:

a) The viewing box (side view) confined the kestrel and maintained stimulus-presentation distance (SPD) so that stimulus-discrimination distance (SDD) was known. The viewing box in conjunction with viewing tunnels directed the subject's view to the stimuli on the stimulus unit (see b) below), and the feeder unit delivered food rewards (see c) below).

b) The stimulus unit (front view) included a board that carried four test- and control-stimulus pairs. The paired rectangles in the lower left quarter of the board indicate the field of view seen through the viewing tunnels. The board rotated to bring different stimulus pairs into the subject's view from one trial to the next. Two pairs presented the test stimulus to the left of the control stimulus, and two pairs presented the test stimulus to the right.

c) The feeder unit (side view) reinforced kestrels with food rewards of ground quail that were extruded from a syringe (S). A baffle (b) and vertical board (at far left) masked the unit from the kestrel. Motor M1 lifted the food syringe up and down to make the syringe accessible, and inaccessible, to the subject through a hole in the vertical board. Motor M2 advanced the syringe plunger to deliver rewards. (ms - microswitch)

The following results were obtained. At the short SPD (21 cm), the acuities of three birds were: 3.2, 3.9, 5.0 cyc./deg. At intermediate SPDs (92 cm and 100 cm), acuities of 9.0, 11.8, 20.3 cyc./deg. were obtained from three birds. At a longer SPD (200 cm) acuities of 12.1 and 15.2 cyc./deg were obtained from two birds (see Fig. 2). Careful control of SDD in this study probably accounts for the differences in acuity reported here and those of earlier studies (e.g., Fox et al. 1976). Thus, the acuity of American kestrels appears to be lower than has been commonly assumed for diurnal raptors (Johnsgard 1990, Walls 1942) and lower than previous reports indicated (Fox et al. 1976, Hirsch 1982, McIsaac et al. - submitted to NREL).

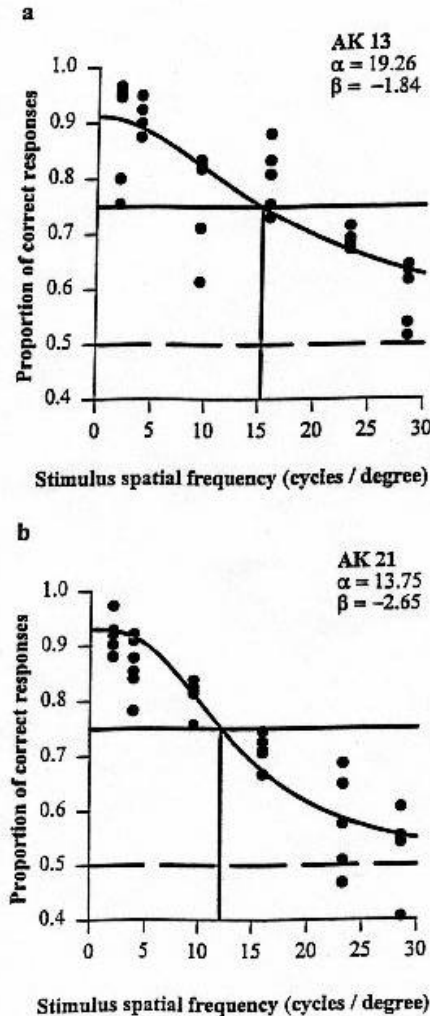

FIGURE 2. Visual acuities of two American kestrels tested at a 200 cm SPD. *These psychometric curves illustrate the kind of data, and its analysis, obtained in our acuity studies. Analysis of such data includes the fitting of logistic curves and calculation of acuity, in cycles/degree of stimulus-grating spatial frequency. Acuity is derived from the logistic regression at the 0.75 rate of correct discrimination. The solid horizontal lines depict the 0.75 correct-discrimination rate, and the vertical lines indicate acuities. The dashed line represents a random performance with a correct-discrimination rate of 0.5. Inflection point and slope of the logistic curves are specified by **a** and **b**, respectively.*

Additionally, the results of this study and Study 1 suggest an effect of SPD on acuity (see

Fig. 3). All of the acuities obtained at SPDs of less than 76 cm were lower than those obtained at the longer SPDs. One possible interpretation of these data suggests that kestrels view close objects with one visual field of low acuity, and more distant objects with a different visual field of higher acuity; a parallel situation has been documented in pigeons (Blough 1973). Although we did not attempt to document the use of different visual fields with different SPDs, Frost et al. (1990) suggest that kestrels use one visual field when viewing close objects (less than 1 - 1.5 m) and a second visual field with more distant objects.

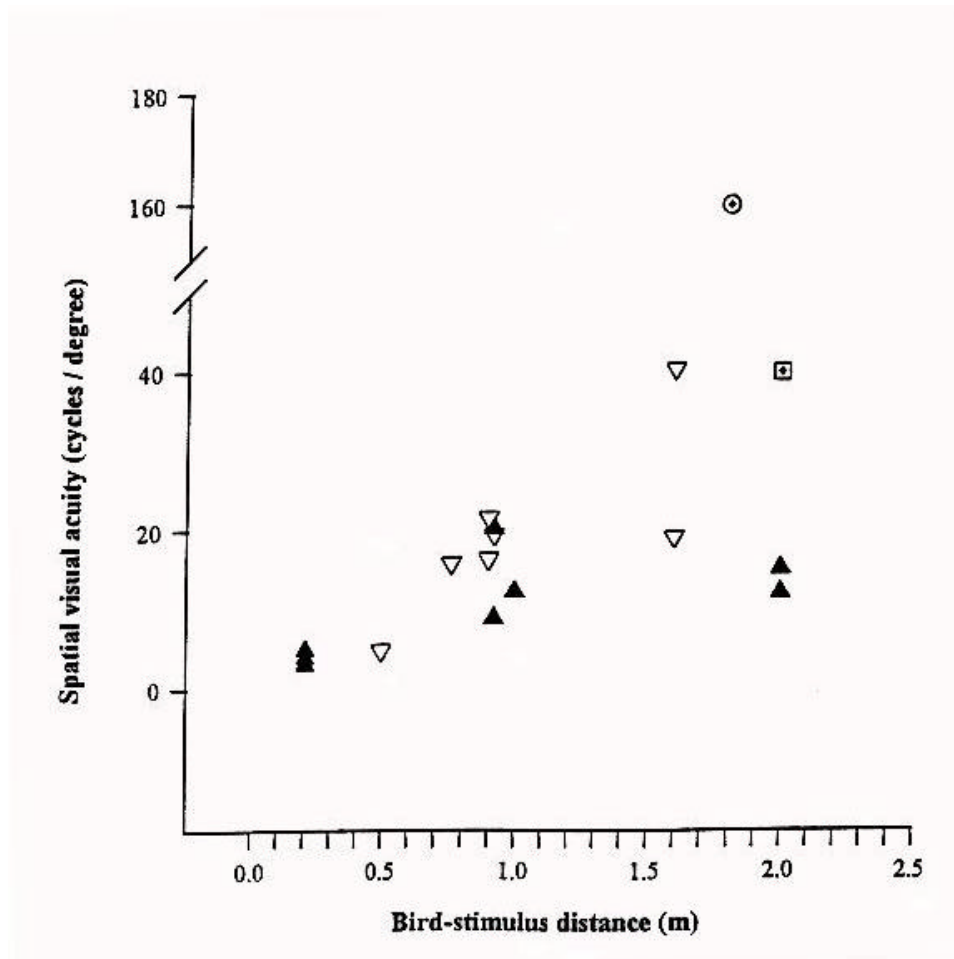

FIGURE 3. Relationship between kestrel visual acuities and the distance separating bird and stimulus. The kestrel acuities obtained in this study are represented by filled black triangles. Kestrel acuities reported by McIsaac et al. (submitted to NREL, open triangles), Hirsch (1982, open square with cross-hairs), and Fox et al. (1976, open circle with cross-hairs) are presented for comparison with this study. Each symbol represents the acuity of a single subject. Note that the only acuity above 40 cyc./deg. is that reported by Fox et al. (1976).

**Study 3 - Visual Acuity in American Kestrels and the Influence of Stimulus Rotation on Acuity** (McIsaac and Whitlock (b) - submitted to NREL). In this study we examined the effects of rotation on acuity; rotation is an important feature of wind turbines and likely contributes to raptor fatalities in the Altamont Pass wind-resource area. Visual acuities of two American kestrels were obtained with four stimulus-rotation rates: 0, 43, 68.5, and 90 rpm. The black-and-white lines of the test stimulus were arranged radially around the center of stimulus rotation, rather than as a pattern of parallel lines. Thus, the black-and-white lines of the test stimuli were arranged as the teeth of a gear, and a gray annulus served as the control stimulus (see Fig. 4). Other than the stimuli the procedure and apparatus used in this study were similar to those used in Study 2.



FIGURE 4. Stimulus-presentation unit used in the rotation-study. *This unit presented the test- and control-stimuli in left or right positions. Only those portions of the two stimuli encompassed by the dashed lines in this diagram were visible through the viewing tunnels. The test stimulus had solid black centers surrounded by annuli of radiating black-and-white spokes, while the control stimulus had solid black centers surrounded gray annuli. One motor (M1) rotated the large supporting discs so that the positions of CS and US could be switched between one trial and the next, and another motor (M2) rotated the individual stimuli during trials.*

Visual acuities were obtained from both kestrels with all stimulus-rotation rates except 0 rpm; we obtained an acuity from one bird only with 0 rpm. The acuities obtained were: 13 cyc./deg. with 0 rpm, 3 and 2 cyc./deg. with 43 rpm, 2 and 1 cyc./deg. with 68.5 rpm, and 1 and 1 cyc./deg. with 90 rpm (see Fig. 5). These acuities are low and indicate that moderate motion significantly

influences kestrel acuity. The effect of stimulus rotation on visual resolution appears pronounced even with the slower rotation rates. These results suggest that kestrels may be unable to clearly resolve all portions of turbine blades under some conditions. Particularly difficult conditions likely include blade rotation, low contrast of blade against background, and dim illumination.

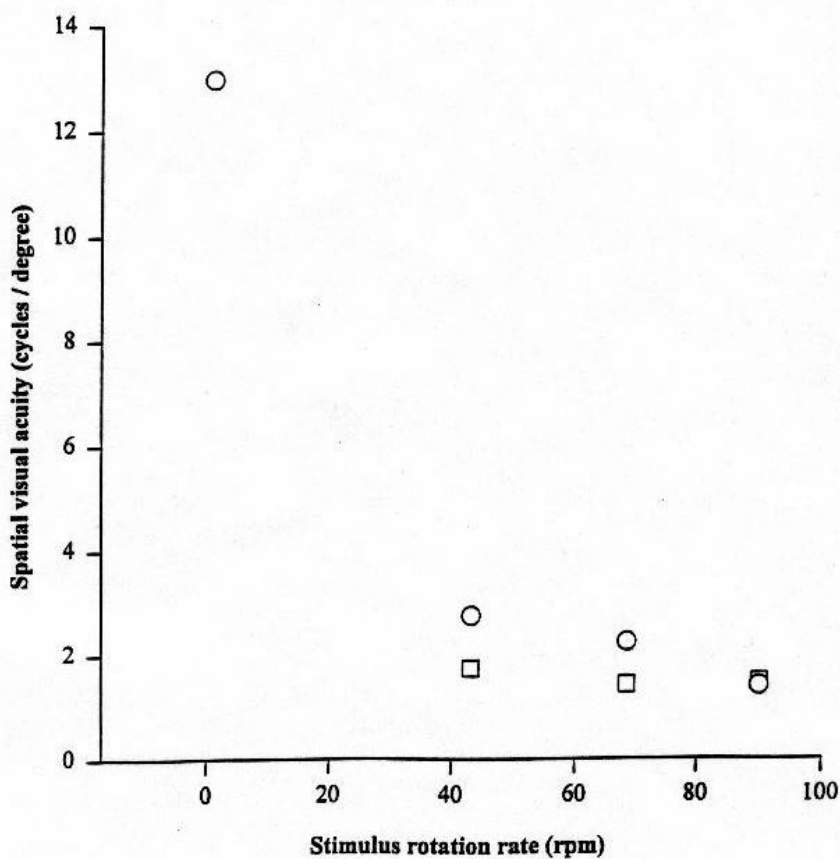

FIGURE 5. Effects of stimulus rotation on kestrel acuity. *The effects of stimulus rotation on acuity are shown for two American kestrels. Kestrel Ak22 is represented by circles and Ak14 by squares. Each symbol represents an acuity derived from psychometric curves similar to those presented in Fig. 2.*

**Study 4 - Visual Acuity of a Red-Tailed Hawk** (McIsaac and McDonald (a) - submitted to NREL). After determining that kestrel acuity did not match previous expectations we tested a second, and larger, raptor species to determine if other species also exhibited lower acuity than expected. The visual acuity of a red-tailed hawk was measured using an apparatus similar to that of Study 2, but larger (see Fig. 6). Acuity was found to be 16.8 cyc./deg. when tested with stationary stimuli and 83 cm SPD/SDD (see Fig. 7). Unfortunately, we were forced to terminate this study prematurely and could not test more than one bird. This finding is consistent with our results concerning kestrel acuity and suggests that hawk acuity, like that of the kestrel, may be relatively unremarkable.

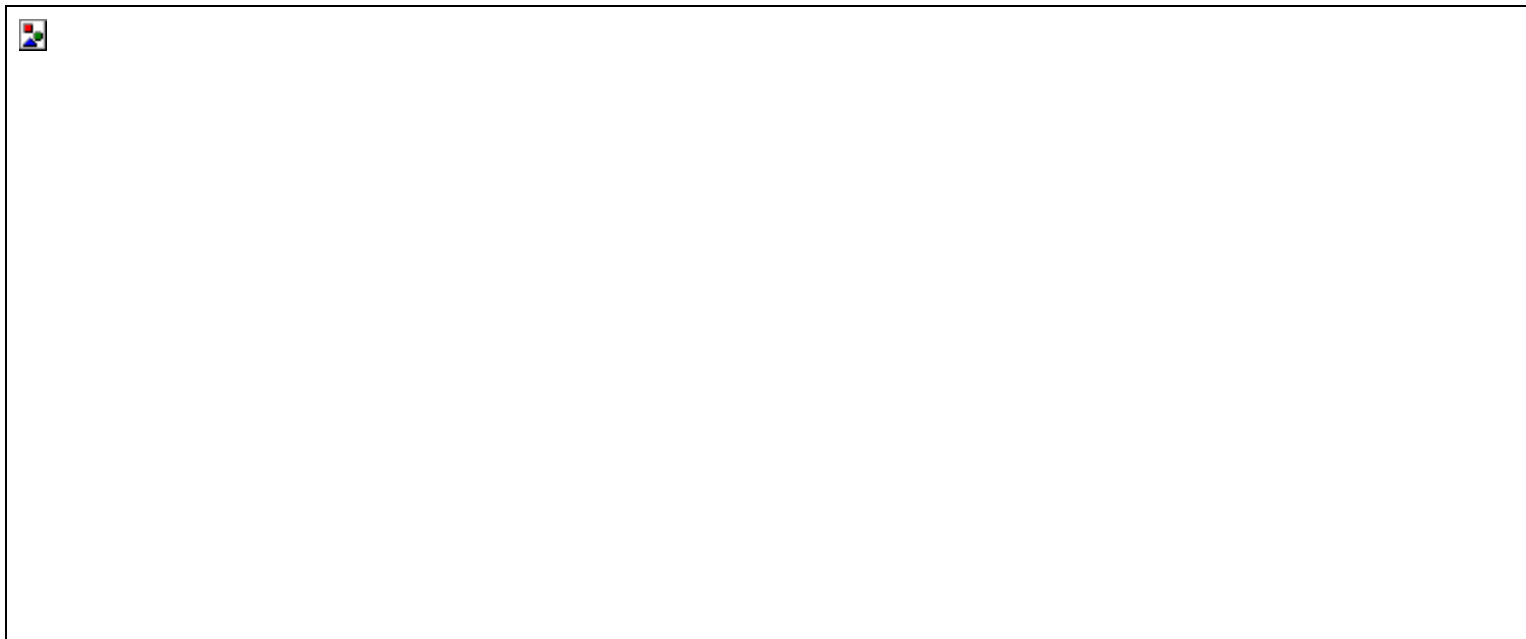

FIGURE 6. Test apparatus used to test hawk acuity.

*This apparatus is larger, but otherwise functioned almost identically to the apparatus shown in Fig. 1. Only the critical components are shown; supporting structures, drive motors, and electrical connections have been omitted. The computer that controls the apparatus has been omitted as well. The principal components included a bird box (Bb) to contain the hawk and maintain SPD, stimulus-presentation device (St), and feeding unit (Fe) that delivered food from a syringe (Sy). Ba - baffle, Fp - feeder port, P - partition, Sh - shutter, Vw - viewing windows.*

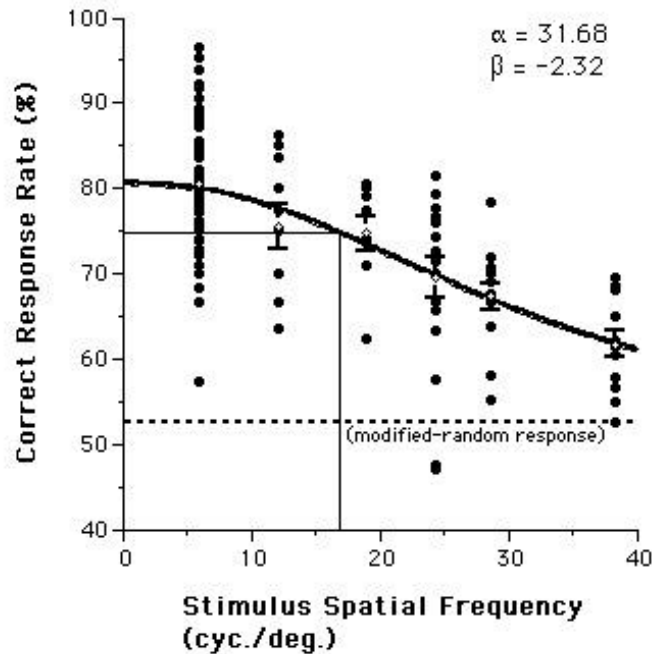

FIGURE 7. Visual acuity of a red-tailed hawk. This psychometric curve shows the hawk's discrimination performances with a variety of test-stimulus-grating frequencies. Acuity, obtained from the modified logistic curve, falls at 16.8 cyc./deg. Inflection point and slope of the logistic curve are specified by  $\alpha$  and  $\beta$ , respectively. Open diamonds represent the mean correct-response rate with each grating frequency. The error bars show one standard error from the mean; for those means not showing error bars the bars were too small to represent in the diagram.

Because we had obtained acuities from two raptor species that were lower than expected we decided to test the acuity of a well-studied bird, the pigeon, to make sure that our procedures were appropriate. We obtained acuities from two pigeons (see Fig. 8), and these fell within the normal range of pigeon acuities that have been obtained by others (Blough 1973, Güntürkün and Hahmann 1994, Hahmann and Güntürkün 1993, Hodos et al. 1985).

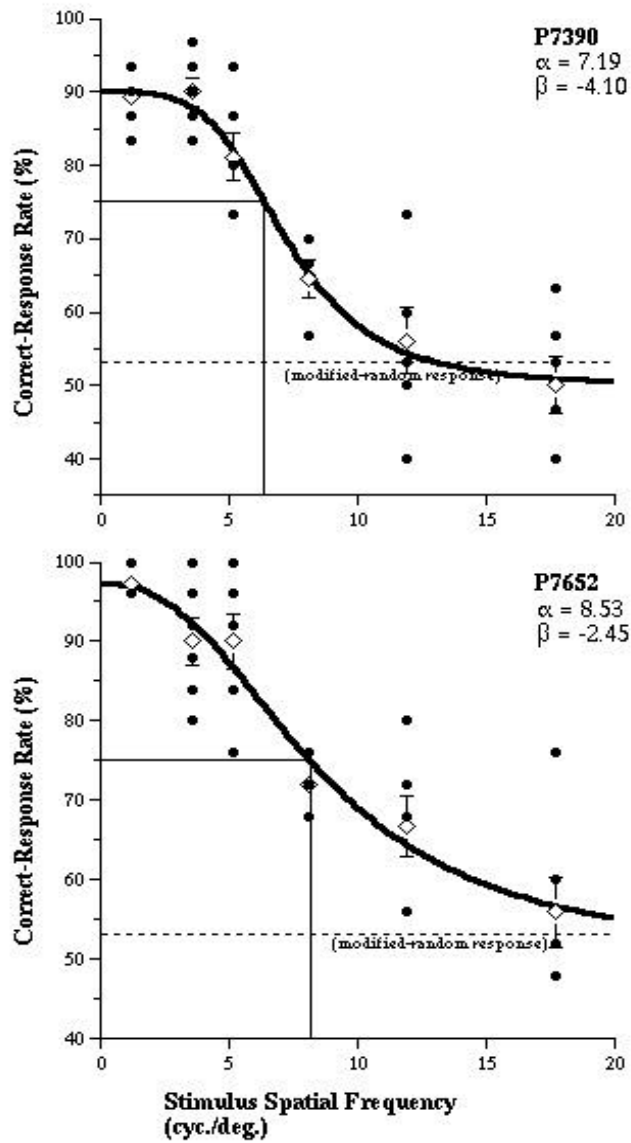

FIGURE 8. Psychometric curves and visual acuity estimates for two pigeons. The upper diagram presents the results for pigeon 7390 with an acuity of 6.4 cyc/deg. The lower diagram presents pigeon 7652 with an acuity of 8.1 cyc/deg. Refer to Fig. 2 for an explanation of graph features.

Our results from Studies 1-4 indicate that the visual acuity of raptors is only moderate, and not exceptional as had been previously thought (e.g., Fox et al. 1976, Johnsgard 1990, Walls 1942). Two studies of American kestrels indicate that kestrel acuity falls below human capacity and that rotation dramatically reduces acuity. In addition, red-tailed hawk acuity also appears to be moderate rather than exceptional. These results suggest that raptors may not clearly see rotating turbine blades under some environmental conditions such as dim illumination (overcast, dusk to dawn) and low contrast (haze, fog, or overcast).

**Study 5 - Effects of Patterns on Blade Conspicuity of Propeller-type Rotors** (McIsaac and Chastain - submitted to NREL). This study of pattern conspicuity was conducted with human subjects because these data could be obtained quickly and the results were used to design a blade-pattern conspicuity study involving raptors (see Study 6). Raptors and humans share many of the basic features of the vertebrate eye (Tansley 1965). We report the relative visual conspicuities, as perceived by humans, of six patterns presented on three-bladed representations of turbine rotors. Conspicuity estimates were obtained of full-blade lengths and of the distal-quarter blade (tip).

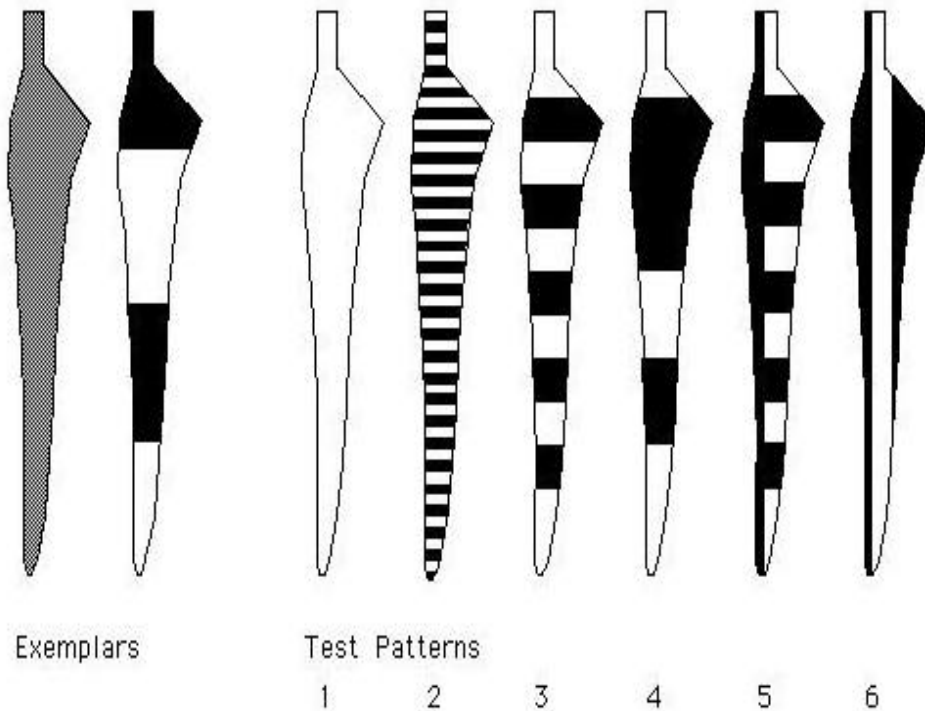

FIGURE 9. Human-perceived blade-pattern conspicuity: stimulus blade patterns.

*In order to obtain human-perceived conspicuity ratings of blade patterns, college students rated the conspicuities of six test patterns relative to standardized conspicuities of two exemplars. This human-based study provided a quick assessment of pattern conspicuity based on a fairly generalized*

*vertebrate eye.*

College students evaluated blade-pattern conspicuity in this study. Before the start of the study subjects received explanations of the purpose, objectives, and procedures of the study. At this time subjects were shown two exemplars of blade patterns (see Fig. 9) against which they were to compare the test patterns. This provided a common basis on which the responses of all subjects were standardized; the two exemplar patterns demonstrated relatively high and low conspicuities. With the exemplars to anchor their ratings the subjects ranked the full-blade visibility of the six test patterns (see Fig. 9) on a scale of 0 to 100 and the blade tips as clearly visible (1.0) or not clearly visible (0.0).

Blade patterns were tested under a variety of conditions. First, the three-bladed rotor stimulus was either rotating or stationary. The stimuli were rotated at approximately 88 rpm, slightly faster than Green Ridge Power's 56-100 turbines (Gipe 1995). Second, illumination conditions were manipulated to alter stimulus brightness and contrast. A third test condition, the background against which the stimulus rotor blades were viewed, also was varied between a uniformly blue-gray background and a mottled background of tan patches on a blue-gray background. A black curtain blocked the subjects' views of the stimuli while patterns, rotation, and illumination were changed between trials.

The results demonstrate that blade patterns differed significantly in conspicuity (see Fig. 10, Table 1a and b). Patterns with components running across the width of the blades tended to be more conspicuous than either those with components running the length of the blades and those with uniformly colored blades. Other factors significantly influencing conspicuity included stimulus rotation, illumination, and under some conditions, background. Significant interactions were obtained among these factors and blade patterns (Table 1a and b).

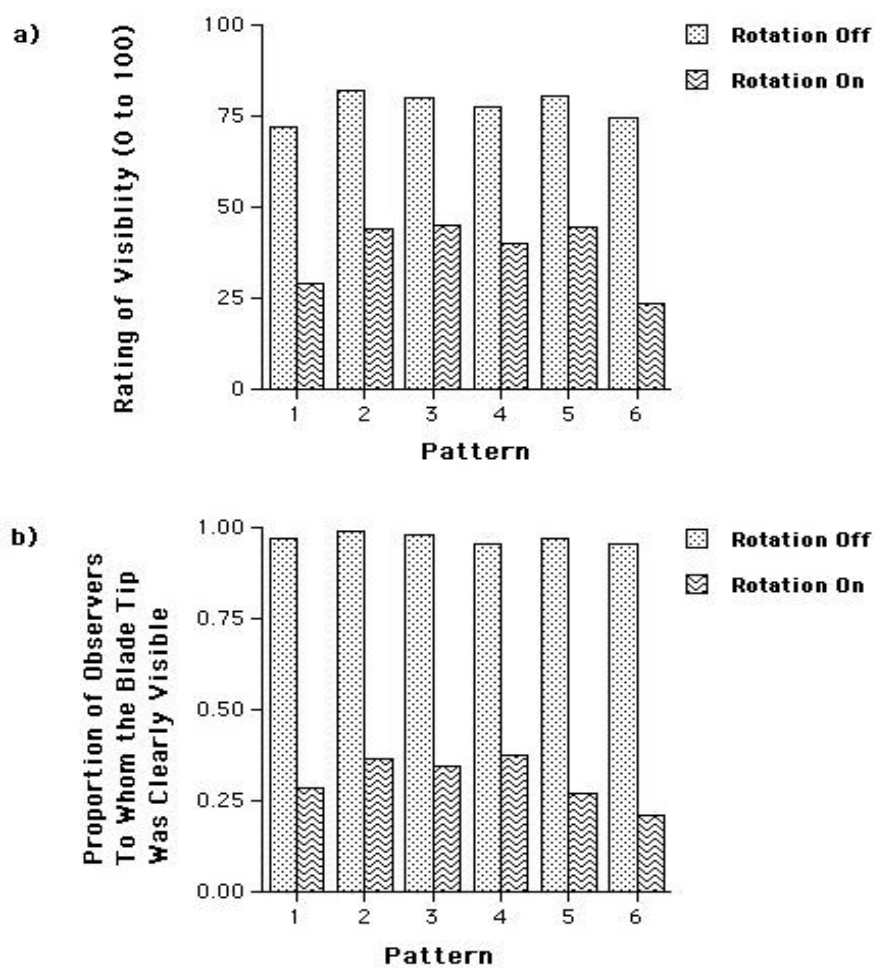

FIGURE 10. Human-perceived blade-pattern conspicuity: two-factor interactions of pattern and rotation. These diagrams show the relationship between blade-pattern conspicuity and the effects of rotation. Illustrations of the blade patterns are presented in Fig. 9. Both blade pattern and rotation significantly affected conspicuity. Two ratings of pattern conspicuity are presented, a) full-blade visibility ratings, b) blade-tip visibility ratings.

TABLE 1. Human-perceived blade-pattern conspicuity. *The main effects of the four experimental factors are listed independent of significance. All combinations among factors were tested for interactions, however, only those significant at a probability level of 0.05 and less are shown.*

(a) ANOVA results for the full-blade visibility ratings.

| <b>ANOVA</b>              | <b>Factor</b>                            | <b>F</b> | <b>df</b> | <b>p</b> |
|---------------------------|--|----------|-----------|----------|
| Main effects              | i) pattern                               | 47.47    | 5         | 0.0000   |
|                           | ii) rotation                             | 641.27   | 1         | 0.0000   |
|                           | iii) illumination                        | 58.75    | 3         | 0.0000   |
|                           | iv) background                           | 0.56     | 1         | 0.4551   |
| Two-factor interactions   | i) pattern x rotation                    | 19.63    | 5         | 0.0000   |
|                           | ii) pattern x illumination               | 13.12    | 15        | 0.0000   |
|                           | iii) rotation x illumination             | 31.03    | 3         | 0.0000   |
| Three-factor interactions | i) pattern x rotation x illumination     | 11.37    | 15        | 0.0000   |
|                           | ii) rotation x illumination x background | 3.03     | 3         | 0.0296   |

(b) ANOVA results for the blade-tip visibility rating.

| <b>ANOVA</b>              | <b>Factor</b>                        | <b>F</b> | <b>df</b> | <b>p</b> |
|---------------------------|--------------------------------------|----------|-----------|----------|
| Main effects              | i) pattern                           | 6.91     | 5         | 0.0000   |
|                           | ii) rotation                         | 935.30   | 1         | 0.0000   |
|                           | iii) illumination                    | 47.30    | 3         | 0.0000   |
|                           | iv) background                       | 3.25     | 1         | 0.0741   |
| Two-factor interactions   | i) pattern x rotation                | 4.53     | 5         | 0.0005   |
|                           | ii) pattern x illumination           | 6.24     | 15        | 0.0000   |
|                           | iii) pattern x background            | 3.78     | 5         | 0.0023   |
|                           | iv) rotation x illumination          | 49.24    | 3         | 0.0000   |
| Three-factor interactions | i) pattern x rotation x illumination | 4.86     | 15        | 0.0000   |

|  |     |                                       |      |   |        |
|--|-----|---------------------------------------|------|---|--------|
|  | ii) | pattern x<br>rotation x<br>background | 2.39 | 5 | 0.0366 |
|--|-----|---------------------------------------|------|---|--------|

**Study 6 - A Method to Assess Animal Perception of Stimulus Conspicuity with Application to Patterned Wind-turbine Blades Using an American Kestrel** (McIsaac and McDonald (b) - submitted to NREL). In this study we developed a new method to assess the relative conspicuities of patterns based on the responses of the target organism, in this case the American kestrel. Although we were forced to terminate this study prematurely (resulting in a small sample size), our results demonstrate the effectiveness of the method, and provide support for the concept that patterns conspicuous to humans (e.g., Study 5) also are conspicuous to raptors. A kestrel was trained to discriminate patterned (experimental) stimuli from uniformly gray (control) stimuli using a forced-choice procedure. The stimuli simulated the three-bladed turbine rotors of commercial wind turbines in relative dimension and motion (see Fig. 11). The blades of the experimental rotor stimulus carried one of several test patterns (see Fig. 12), and the background behind the rotor was uniformly gray. A similar turbine-rotor representation and background served as the control stimulus, except that the control blades were uniformly gray with only a black outline. Both test- and control-stimulus rotors rotated at 30 rpm. As with our other studies based on two-stimulus forced-choice procedures, the test- and control-stimulus rotors were randomly switched between left and right positions. The kestrel discriminated the test- and control-stimulus rotors under a range of stimulus-illumination levels selected to produce psychometric curves with discrimination rates that tended to be high with brighter stimulus illumination, e.g., 2.0 Lux, and to decline toward random as illumination dimmed, e.g., 0.02 Lux. Multiple-regression analysis of logistic curves fit to the bird's discrimination performance with each blade pattern provided the basis for comparing conspicuities among different patterns.

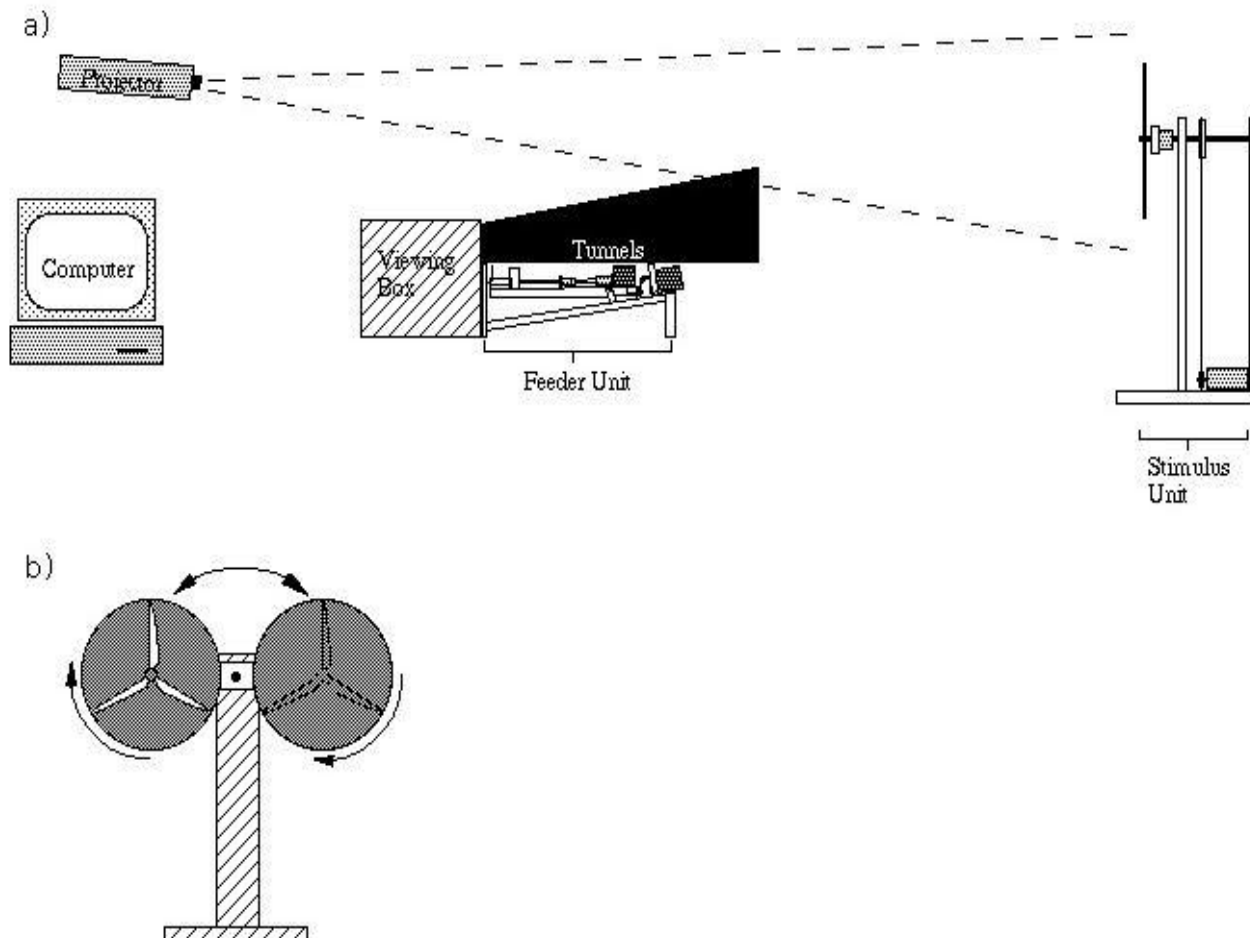

FIGURE 11. Kestrel-perceived blade-pattern conspicuity: the experimental apparatus. a) The experimental apparatus comprised four principal parts, as shown here in side view. *First, a viewing box confined the kestrel and directed its view toward the stimuli. Second, a stimulus unit presented stimuli of three-bladed rotors showing the various blade patterns. The stimuli were illuminated by a slide projector, and neutral-density filters were used to regulate illumination of the stimuli. Third, a feeder unit delivered food rewards of ground meat. Finally, a computer regulated the apparatus and recorded data. However, the neutral-density filters were operated by hand.* b) Frontal view of the stimulus unit.

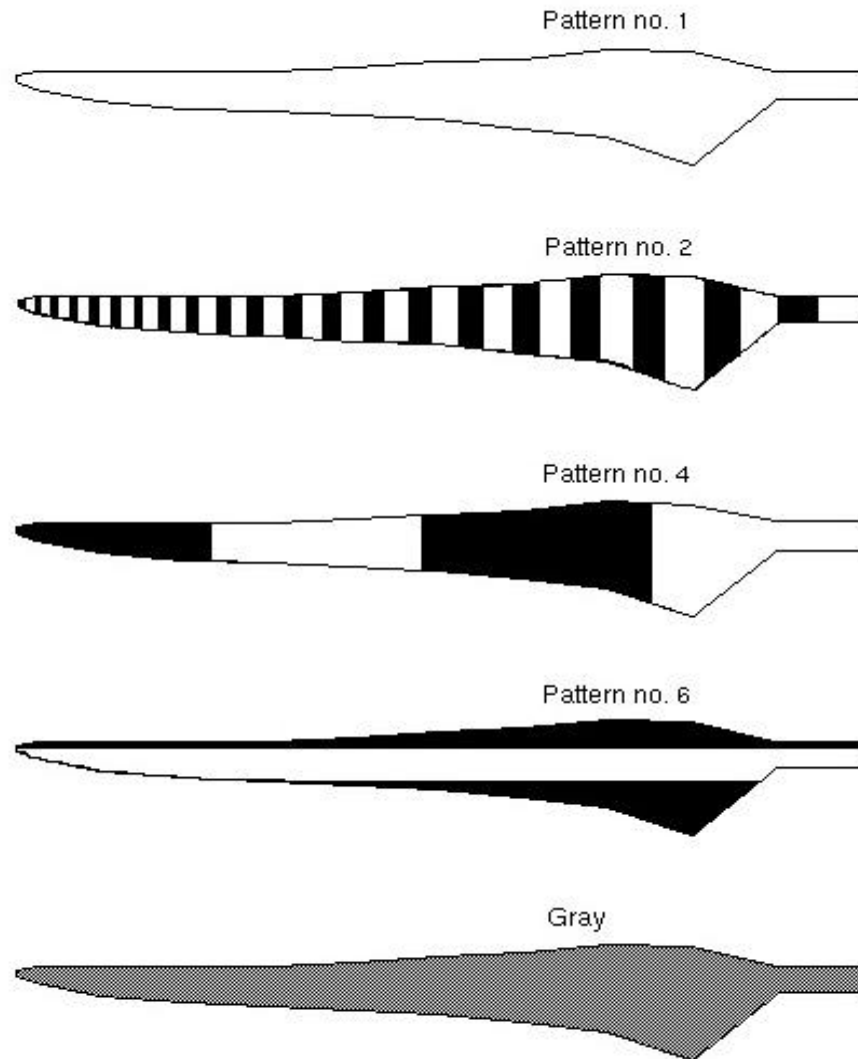

FIGURE 12. Kestrel-perceived blade-pattern conspicuity: stimulus blade patterns. *Depicted are the four black-and-white test patterns and the gray control pattern that were used to determine pattern conspicuity as perceived by a kestrel.*

We found that the relationship between discrimination rate and stimulus-illumination varied significantly among patterns (Table 3 - refer to McIsaac and McDonald (b) for additional details of the statistical analysis), and, thus, that patterns differed in relative conspicuity (see Fig. 13). A pattern of two broad black bands (pattern no. 4) running across the width of the white blade provided the highest conspicuity of the patterns tested. A plain white blade, pattern no. 1, also provided relatively high conspicuity. A pattern of stripes running the length of the blades (pattern no. 6) was less conspicuous, while fine stripes running across the width of the blades (pattern no. 2) provided the lowest conspicuity rating. However, the results of Studies 2 and 3 indicate that the kestrel could not resolve the fine stripes of this pattern under the conditions presented, which

explains its low conspicuity. The results of Study 5 and this study suggest that carefully selected blade patterns will increase the conspicuity of turbine-rotor blades in the field. Tentatively, we recommend a pattern composed of square-wave, black-and-white components that run across the blade width. See below for additional discussion of blade pattern specifications.

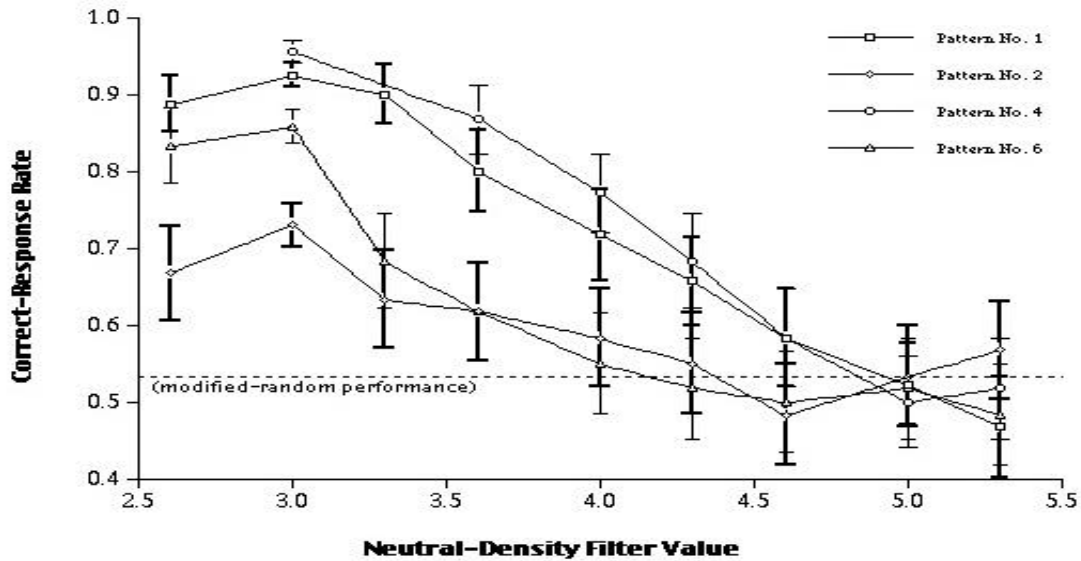

FIGURE 13. A Kestrel's conspicuity rating of four blade patterns. *Discrimination performances of a kestrel serve as a measure of conspicuity of four blade patterns (see Fig. 12 for illustrations of the blade patterns). Each pattern was tested at several illumination levels. In this diagram the X axis, neutral-density filter value, represents illumination level. Discrimination performances, proportion of correct responses with binomial standard deviations (vertical bars), are shown for each blade pattern and illumination level. Where standard deviations are not shown the bars were too short to represent in the diagram.*

TABLE 3. Kestrel-perceived blade-pattern conspicuity: Odds ratios for the logistic regression analyses. *Those patterns that did not differ significantly from pattern no. 1 (see Fig. 12) are not included in this table. The odds ratios for shaded cells are not statistically different from pattern no. 1, based on 95% confidence intervals for the odds ratios.*

| Filter               | 2.6  | 3.0  | 3.3  | 3.6  | 4.0  | 4.3  | 4.6  | 5.0  | 5.3  |
|----------------------|------|------|------|------|------|------|------|------|------|
| <b>Pattern no. 2</b> | 0.10 | 0.14 | 0.18 | 0.24 | 0.33 | 0.43 | 0.55 | 0.76 | 0.98 |
| <b>Pattern no. 4</b> | 2.39 | 2.09 | 1.90 | 1.72 | 1.51 | 1.37 | 1.24 | 1.09 | 0.99 |

***Study 7 - Categorical Discrimination in American Kestrels*** (McIsaac - submitted to NREL). The capacity of raptors to learn and generalize what they learn to new situations may prove important in developing mitigation procedures to reduce raptor fatalities in the Altamont Pass. In order for raptors to generalize they must have the capacity to associate new situations with those present when learning took place, i.e., they must group both types of situations as belonging to the same category. For example, if raptors learn to avoid a specific set of turbines, then in order for them to generalize to avoid all turbines they must categorize all turbines as a group of related objects.

In order to test the capacity of raptors to recognize objects as members of one category or another, I relied on a go/no-go psychometric method (Blough and Blough 1977), rather than the two-stimulus forced-choice method described above. Go/no-go methods are similar to forced-choice methods in that both procedures measure a bird's capacity to discriminate between stimuli. In the case of the go/no-go procedure, however, only one stimulus is presented at a time. Two kestrels learned to discriminate color photographs of grassy hillsides containing wind turbines (including supporting towers, nacelles, and blades), set against mostly cloudy skies, from those of grassy hillsides set against mostly cloudy skies and without turbines. Photographs containing turbines varied in the number of turbines shown and presented the turbines from a variety of perspectives. Several examples, converted to black-and-white representations, of the color photographic stimuli are shown in Fig. 14. The color photographic images were projected from 35 mm color slides onto a rear-projection screen. The kestrels viewed each stimulus through a single window in the front of the viewing box (see Fig. 15).

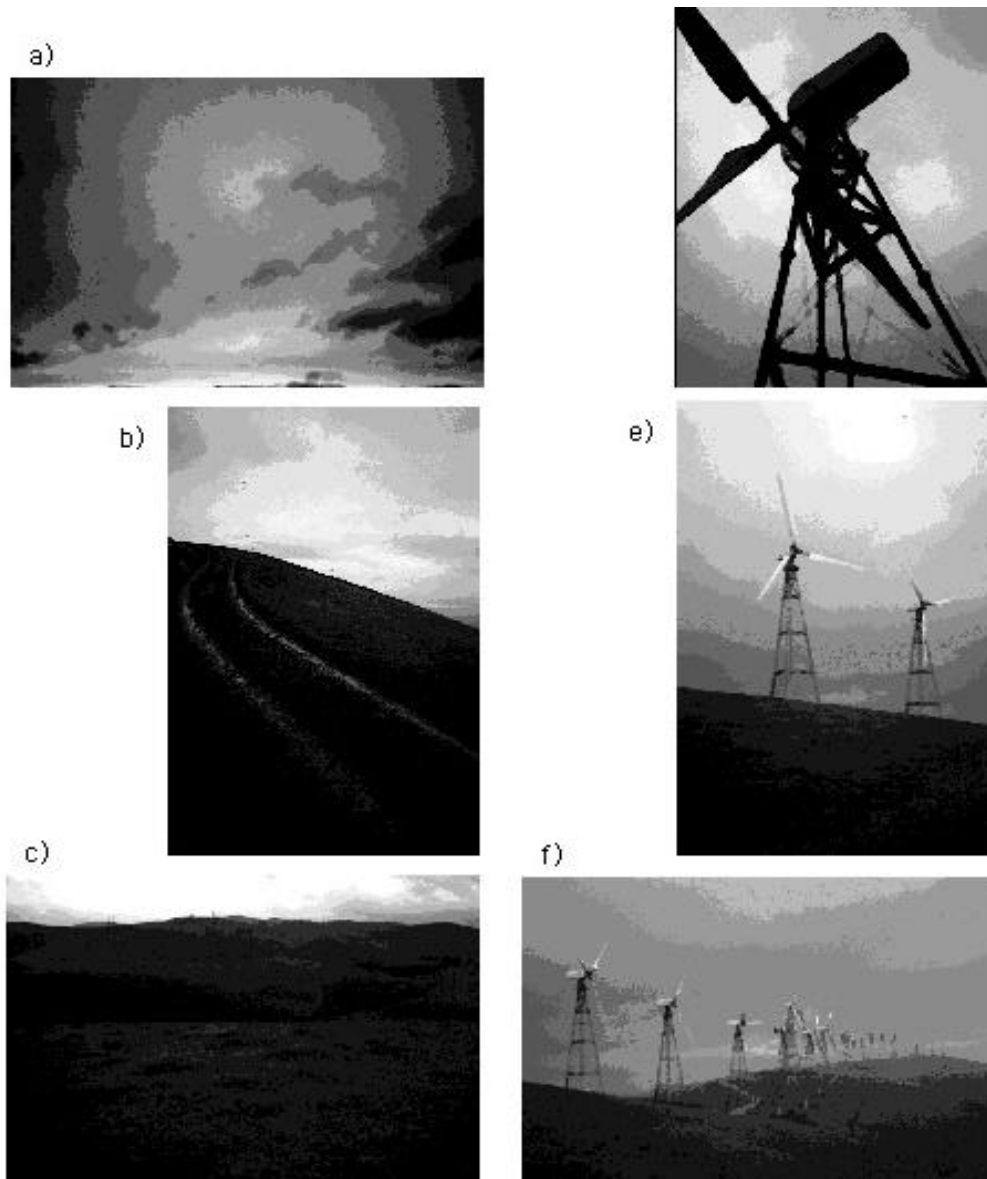

FIGURE 14. Examples of photographs used to demonstrate category formation and discrimination in kestrels. These black-and-white representations of color photographs show a few of the hundreds of photographs used to train and test two American kestrels to discriminate photographs showing wind turbines from those lacking turbines.

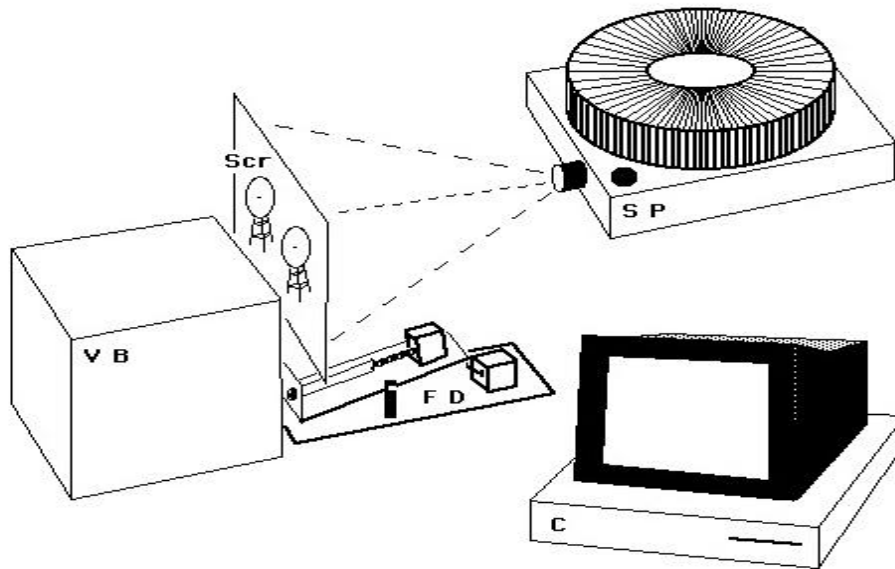

FIGURE 15. Training and test apparatus used to study category formation and discrimination in kestrels. *Four principal components composed the apparatus: a viewing box (VB), a food dispenser (FD), a slide projector (SP) with rear-projection screen (Scr), and a computer (C). Only critical components are shown; supporting structures and electrical connections have been omitted.*

As with the forced-choice method, the birds observed the stimulus from a perch located near the front of the viewing box. If a given stimulus photograph contained wind turbines, the bird could indicate this by thrusting its head into the window and receiving a food reward through the computer-controlled apparatus. If, however, the photograph lacked turbines, the bird could indicate this by refraining from thrusting its head through the viewing window<sup>3</sup> until the computer removed the stimulus (ten seconds). Alternatively, the bird could indicate an absence of turbines in the photograph by hopping to a perch at the rear of the viewing box. No food reward was given for appropriate responses to photographs without turbines. On the other hand, when the bird responded inappropriately to either stimulus type, that is, head thrust into viewing window in response to a photograph without turbines or absence of a head thrust (wait or hop to rear perch) in response to a photograph containing turbines, a ten second delay was imposed before the presentation of the next stimulus photograph.

The kestrels were trained to discriminate photographs of turbines from photographs without turbines using the same set of 40 training photographs again and again. The presentation sequence of the two photograph types was randomized so that the birds could not predict what photograph type would be presented next. After the kestrels had mastered the training photographs, critical-tests were performed with 210 photographs the birds had never seen before. Each novel

<sup>3</sup> While this is a standard component of go/no-go procedures, the kestrels appeared to have difficulties waiting without responding in some way. This generated a very high error rate until a perch was installed at the rear of the viewing box and provided an alternative mechanism for the birds to indicate stimuli without turbines.

photograph was shown only once during each kestrel's critical tests.

Both kestrels demonstrated a capacity to categorize, into groups, objects with which they were not directly familiar. They correctly identified both photographs containing turbines and those without turbines in approximately 96% of the critical-test trials (see Fig. 16). These performances were significantly above random based on statistical analysis using the Test of Significance of a Binomial Proportion (Snedecor and Cochran 1967), kestrel Ak19:  $Z_C = 12.582$ ,  $p \ll 0.0001$ ; kestrel Ak16:  $Z_C = 12.444$ ,  $p \ll 0.0001$ . These results provide the first demonstration of categorical discrimination in a raptor.

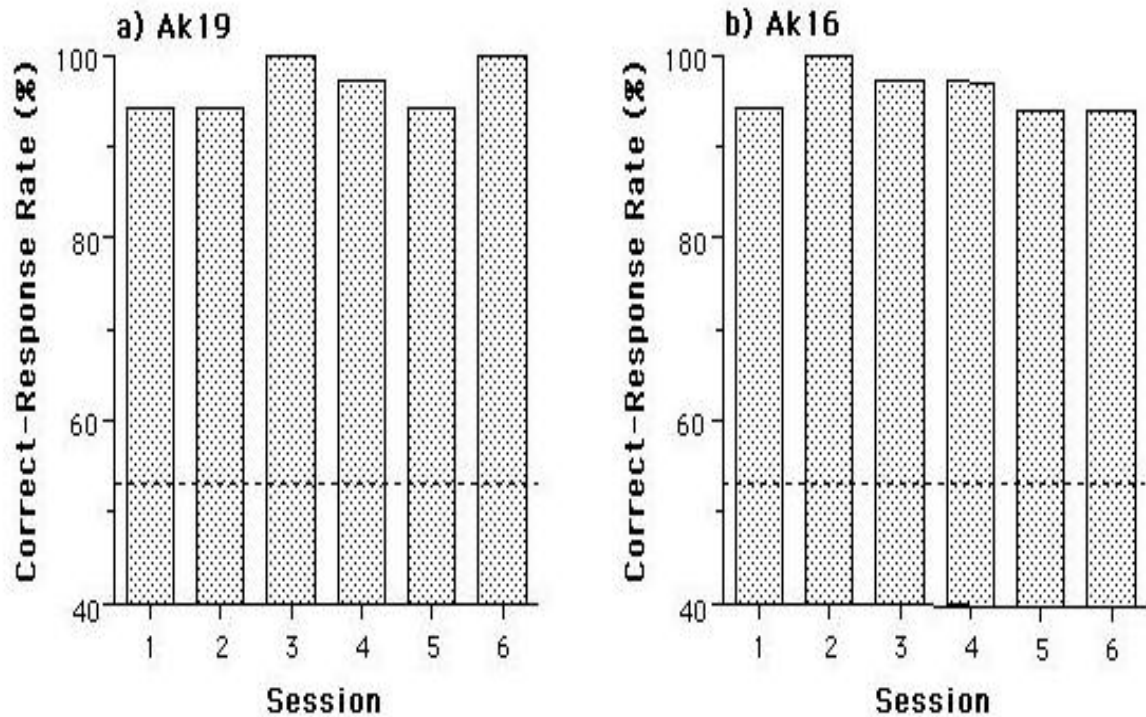

FIGURE 16. Category formation and discrimination in American kestrels. Two kestrels, a) Ak19 and b) Ak 16, successfully discriminated between photographs showing wind turbines and similar photographs lacking turbines (see Fig. 14); the kestrels' discrimination rates significantly exceeded random performance rates. These results demonstrate that kestrels are capable of grouping objects into categories. Random performances would have fallen at the level of the dashed lines. The dashed lines at the 53.1% correct-response rate represents a modified-random performance (Mclsaac - submitted to NREL).

The capacity to categorize objects may enable kestrels to learn information about a group of objects, such as wind turbines, and to associate such information with members of the group never before encountered. Such a capacity could provide the basis of mitigation procedures to deter close contact with turbines, or to avoid turbines altogether. See McIsaac and Fuller (submitted to NREL) for additional discussion of this topic. Aversive-conditioning procedures intended to keep California condors away from dangerous man-made structures are being used with condors (Davis and Sorenson NAWPPM IV); such procedures require the capacity to group objects into categories.

## Discussion of Findings

Our results indicate that raptors may not clearly see turbine blades under some environmental conditions, and that applying high-contrast patterns to turbine blades may increase the conspicuity of the blades. Based on the results from all of our studies we make several recommendations concerning turbine-blade patterns. We tentatively recommend a pattern with square-wave, black-and-white<sup>4</sup> bands that run across the blade (e.g., see Fig. 9, pattern nos. 2-4). Across-blade pattern components produced significantly better conspicuity in our test kestrel (McIsaac and McDonald (b) - submitted to NREL) and in humans (McIsaac and Chastain - submitted to NREL) than did components running the length of the blade. The across-blade components should run the entire width of the blade, front and back (i.e., a band around the blade). However, the distance the component runs along the length of the blade should be set according to the target species' visual acuity, and the distance between blade and bird at which visual resolution is desired, e.g., sufficient distance for the bird to maneuver around the turbine in strong wind.

For a given bird-to-blade distance, pattern components large enough to be resolved by a kestrel also should be large enough to be seen by larger-eyed raptor species such as the Golden Eagle (*Aquila chrysaetos*) and Red-tailed Hawk; these are the three raptor species found dead most frequently in the Altamont Pass wind plant (Howell and DiDonato 1991, Howell and Noone 1992, Orloff and Flannery 1992). For example, blade-pattern components must have at least one dimension extending 20 cm or more in order for kestrels to first resolve the coarsest details of the blade at a distance of 34.4 m. This calculation assumes an acuity of 1.5 cyc./deg., high contrast, bright illumination (McIsaac and Whitlock (b) - submitted to NREL), and a moderate rotational rate (68.5 rpm). The Green Ridge Power 56-100 turbines rotate at 71 rpm (Gipe 1995).

If the bird is flying downwind at 30 mph (air speed) in a 30 mph wind then the resulting ground speed will be 60 mph, which leaves the bird 1.3 seconds until it reaches the blade plane (McIsaac and Fuller - submitted to NREL). Such a short time interval may not leave the bird sufficient time to process the visual information, decide on a course of action, and then execute that action, before it is at risk of striking the blades. Thus, the dimensions of blade-pattern components

---

<sup>4</sup> The white components should reflect in the ultraviolet spectrum as well as in the visible, and the black should absorb in the ultraviolet spectrum as well as in the visible. Ultraviolet spectra should be incorporated into the pattern because birds can see this region of the spectrum (Bennett and Cuthill 1994, Kreithen and Eisner 1978, Parrish et al. 1984, Viitala et al. 1995), and can potentially obtain additional information concerning the pattern and blade from these spectra.

should take into account not only the visual capacities of raptors but also the species flight characteristics and wind conditions in the field. See McIsaac and Fuller (submitted to NREL) and McIsaac and Whitlock (submitted to NREL) for additional discussion of this topic. While I have provided guidelines for the design of turbine-blade patterns based on our laboratory studies, ultimately any blade pattern must be carefully tested in the wind-energy operations environment to verify its effectiveness.

### Acknowledgments

We thank Boise State University, Kenetech Windpower, Inc. (grant no. 04-01-692-L615-43), and the National Renewable Energy Laboratory (contract no. XAM-7-16454-02) who provided financial support for this work. Dr. Thomas Cade, Dr. Mark Fuller, Dr. Melvin Kreithen, Dr. Vance Tucker, and Dr. Charles Walcott provided much-appreciated oversight of the work summarized in this report in their capacity as members of a panel of senior scientists assembled by Kenetech Windpower, Inc. Dr. Dennis McDonald helped design and constructed the computer-driven apparatus. Dan Gossett, Peter Whitlock assisted in the running of experiments and in maintaining the birds, and Greg Draheim and George Carpenter also helped to maintain the birds.

### References

- Bennett, A.T.D.; Cuthill, I.C. (1994). "Ultraviolet Vision in Birds: What is Its Function?" *Vision Research* (34:); pp 1471-1478.
- Blough, P.M. (1973). "Visual Acuity in the Pigeon II: Effects of Targets Distance and Retinal Lesions." *Journal for the Experimental Analysis of Behavior* (20:); pp 333-343.
- Blough, D.; Blough, P. (1977). Animal Psychophysics. In: *Handbook of Operant Behavior*. (Honig, W.K.; Staddon, J.E.R.; eds.). Englewood Cliffs, NJ: Prentice Hall. pp 514-539.
- Davis, J., Sorenson, K. Proactive Approach to Avoiding or Reducing Potential Mortality to California Condors. Presented at the National Avian-Wind Power Planning Meeting IV, Carmel, CA, May 2000.
- Emmerton, J. (1990). Pigeons' Perception of Complex Movement Patterns, Volume VIII. In: *Quantitative Analyses of Behavior*. (Commons, M.L.; Herrnstein, R.J.; Kosslyn, S.M.; Mumford, D.B.; eds.). Hillsdale, NJ: Lawrence Erlbaum. pp 67-87.
- Fox, R.; Lehmkuhle, S.W.; Westendorf, D.H. 1976. "Falcon Visual Acuity." *Science* (192:); pp 263-265.
- Frost, B.J.; Wise, L.Z.; Morgan, B.; Bird, D. (1990). "Retinotopic Representation of the Bifoveate Eye of the Kestrel (*Falco sparverius*) on the Optic Tectum." *Visual Neuroscience* (5:); pp 231-239.

- Gipe, P. (1995). *Wind Energy Comes of Age*. New York: John Wiley & Sons, Inc.
- Güntürkün, O.; Hahmann, U. (1994). "Visual Acuity and Hemispheric Asymmetries in Pigeons." *Behavioral Brain Research* (60:); pp 171-175.
- Hahmann, U.; Güntürkün, O. (1993). "The Visual Acuity for the Lateral Visual Field of the Pigeon (*Columba livia*)." *Vision Research* (33:); pp 1659-1664.
- Harvey, L.O., Jr. (1986). "Efficient Estimation of Sensory Thresholds." *Behavior Research Methods, Instruments, & Computers* (18:); pp 623-632.
- Hirsch, J. (1982). "Falcon Visual Sensitivity to Grating Contrast." *Nature* (300:); pp 57-58.
- Hodos, W.; Bessette, B.; Macko, K.A.; Weiss, S.R.B. (1985). "Normative Data for Pigeon Vision." *Vision Research* (25:); pp 1525-1527.
- Hodos, W., Potocki, A., Storm, T., Gaffney, M. Reduction of Motion Smear to Reduce Avian Collisions with Wind Turbines. Presented at the National Avian-Wind Power Planning Meeting IV, Carmel, CA, May 2000.
- Howell, J.; DiDonato, J.E. (1991). *Assessment of Avian Use and Mortality Related to Wind Turbine Operations, Altamont Pass, Alameda and Contra Costa Counties, California, September 1988 Through August 1989. Final Report*. Work performed by Howell and Associates, San Francisco, CA. Livermore, CA: KENETECH Windpower, Inc.
- Howell, J.; Noone, J. (1992). *Examination of Avian Use and Mortality at a U.S. Windpower, Wind Energy Development Site, Montezuma Hills, Solano County, California. Final Report*. Work performed by Howell and Associates, San Francisco, CA. Fairfield, CA: Department of Environmental Management, Solano County.
- Inzunza, O.; Bravo, H. (1993). "Foveal Topography in the Optic Nerve and Primary Visual Centers in Falconiforms." *The Anatomical Record* (235:); pp 622-631.
- Inzunza, O.; Bravo, H.; Smith, R.L.; Angel, M. (1991). "Topography and Morphology of Retinal Ganglion Cells in Falconiforms: A Study on Predatory and Carrion-Eating Birds." *The Anatomical Record* (229:); pp 271-277.
- Johnsgard, P. (1990). *Eagles, Hawks & Falcons of North America*. Washington: Smithsonian Institution Press.
- Kreithen, M.L.; Eisner, T. (1978). "Detection of Ultraviolet Light by the Homing Pigeon, *Columba livia*." *Nature* (272:); pp 347-348.
- McIsaac, H.P. (submitted to NREL). *Categorical Discrimination in American Kestrels: Final Report to the National Renewable Energy Laboratory*. Work performed by Boise State

- University, Boise, Idaho. Golden, CO: National Renewable Energy Laboratory.
- McIsaac, H.P.; Chastain, G. (submitted to NREL). *Effects of Patterns on Blade Conspicuity of Propeller-type Rotors: Final Report to the National Renewable Energy Laboratory*. Work performed by Boise State University, Boise, Idaho. Golden, CO: National Renewable Energy Laboratory.
- McIsaac, H.P.; Fuller, M.R. (submitted to NREL). *Wind-Turbine Blade Pattern Summary Report to National Renewable Energy Laboratory, DOE*. Work performed by Boise State University, Boise, Idaho. Golden, CO: National Renewable Energy Laboratory.
- McIsaac, H.P.; Gossett, D.N.; Whitlock, P.L. (submitted to NREL). *Visual Acuity of the American Kestrel: Final Report to the National Renewable Energy Laboratory*. Work performed by Boise State University, Boise, Idaho. Golden, CO: National Renewable Energy Laboratory.
- McIsaac, H.P.; McDonald, D. (submitted to NREL, a). *A Method to Assess Animal Perception of Stimulus Conspicuity with Application to Patterned Wind-Turbine Blades Using an American Kestrel: Final Report to the National Renewable Energy Laboratory*. Work performed by Boise State University, Boise, Idaho. Golden, CO: National Renewable Energy Laboratory.
- McIsaac, H.P.; McDonald, D. (submitted to NREL, b). *Visual Acuity of a Red-Tailed Hawk: Final Report to the National Renewable Energy Laboratory*. Work performed by Boise State University, Boise, Idaho. Golden, CO: National Renewable Energy Laboratory.
- McIsaac, H.P.; Whitlock, P.L. (submitted to NREL, a). *Spatial Visual Acuity in American Kestrels and the Influence of Bird-Stimulus Distance on Acuity: Final Report to the National Renewable Energy Laboratory*. Work performed by Boise State University, Boise, Idaho. Golden, CO: National Renewable Energy Laboratory.
- McIsaac, H.P.; Whitlock, P.L. (submitted to NREL, b). *Visual Acuity in American Kestrels and the Influence of Stimulus Rotation on Acuity: Final Report to the National Renewable Energy Laboratory*. Work performed by Boise State University, Boise, Idaho. Golden, CO: National Renewable Energy Laboratory.
- Meyer, D.B. (1977). The Avian Eye and Its Adaptations. In: *The Visual System in Vertebrates*. (Crescitelli, F.; Dvorak, C.A.; Eder, D.J.; Granda, A.M.; Hamasaki, D.; Holmberg, K.; Hughes, A.; Locket, N.A.; McFarland, W.N.; Meyer, D.B.; Muntz, W.R.A.; Munz, F.W.; Olson, E.C.; Reyer, R.W.; eds.). Berlin: Springer-Verlag. pp 550-611.
- Orloff, S.; Flannery, A. (1992). *Wind Turbine Effects on Avian Activity, Habitat Use, and Mortality in Altamont Pass and Solano County Wind Resource Areas 1989-1991. Final Report. March 1992*. Work performed by Biosystems Analysis, Inc., Tiburon, CA. Sacramento, CA. California Energy Commission and Alameda, Contra Costa, and Solano

- County Planning Departments.
- Parrish, J.W.; Ptacek, J.A.; Will, K.L. (1984). "The detection of Near-Ultraviolet Light by Nonmigratory and Migratory Birds." *Auk* (101:); pp 53-58.
- Reymond, L. (1985). "Spatial Visual Acuity of the Eagle *Aquila audax*: A Behavioural, Optical and Anatomical Investigation." *Vision Research* (25:); pp 1477-1491.
- Reymond, L.; Wolfe, J. (1981). "Behavioural Determination of the Contrast Sensitivity Function of the Eagle *Aquila audax*." *Vision Research* (21:); pp 263-271.
- Shlaer, R. (1972). "An Eagle's Eye: Quality of Retinal Image." *Science* (176:); pp 920-922.
- Snedecor, G.W.; Cochran, W.G. (1967). *Statistical Methods, sixth edition*. Ames, Iowa: Iowa State University Press.
- Snyder, A.W.; Miller, W.H. (1978). "Telephoto Lens System of Falconiform Eyes." *Nature* (275:); pp 127-129.
- Tansley, K. (1965). *Vision in Vertebrates*. London: Chapman and Hall, Ltd.
- Viitala, J.; Korpimaki, E.; Palokangas, P.; Koivula, M. (1995). "Attraction of Kestrels to Vole Scent Marks Visible in Ultraviolet Light." *Nature* (373:); pp 425-427.
- Walls, G.L. (1942). *The Vertebrate Eye and Its Adaptive Radiation*. Bloomfield Hills, MI: Cranbrook Institute of Science. Bulletin No. 19.

### **General Discussion**

Asked whether he had considered using video footage to test bird reactions to painted vs. unpainted turbines, Dr. McIsaac agreed that it would be a good idea, but said he had not had the funding or time to do field studies or observations. Preliminary before and after field observations have suggested that painting does make a difference, but there were a number of confounding factors and not enough data from which to draw firm conclusions.

One participant asked whether Dr. McIsaac was finding that birds really were able to recognize turbines in photographic images of wind turbines in the distance. Dr. McIsaac answered that "they were able to tell that there were groups of things (in this case, turbines) that were in the photos. And even parts of wind turbines."